

WINGET

OPERATORS HANDBOOK VIBRATORY COMPACTOR PLATE CP505HD



WINGET LIMITED
PO BOX 41
EDGEFOLD INDUSTRIAL ESTATE
PLODDER LANE
BOLTON, LANCS
BL4 0LR
Tel: ++ 44 (0) 1204 854650
Fax: ++ 44 (0) 1204 854663
parts@winget.co.uk
service@winget.co.uk
www.winget.co.uk

This manual covers
the following models
from serial number

CP505HD-2064575

TABLE OF CONTENTS

<u>Safety Information</u>	1	Exciter Removal & Disassembly	7
Introduction	1	Exciter Assembly Instructions	8
Safety Precautions	1	Exciter Installation	8
Safety Decals	1	<u>Service</u>	7
<u>Specifications</u>	3	Torque Chart	7
<u>Operation</u>	4	Service Tools	7
Introduction	4	Parts Replacement Cycles & Tolerances	8
Before Starting & Operating	4	<u>Replacement Parts</u>	9
<u>Maintenance</u>	5		
		EXCITER ASSEMBLY	14
Maintenance Schedule	5	ENGINE ASSEMBLY	16
Fluid Levels	5	ROLL CAGE	18
Engine Maintenance	5	<u>Warranty</u>	20
Engine Speed	5		
Belt Adjustment	5		
Checking Exciter Oil	6		
Changing Exciter Oil	6		

SAFETY INFORMATION

Introduction



This Safety Alert Symbol is used to call attention to items or operations which may be dangerous to those operating or working with this equipment. The symbol can be found throughout this manual and on the unit. Please read these warnings and cautions, along with all decals, carefully before attempting to operate the unit. Make sure every individual who operates or works with this equipment is familiar with all safety precautions.



GENERAL WARNING. Indicates information important to the proper operation of the equipment. Failure to observe may result in damage to the equipment and/or severe bodily injury or death.



GENERAL CAUTION. Indicates information important to the proper operation of the equipment. Failure to observe may result in damage to the equipment.

Safety Precautions



LETHAL EXHAUST GAS: An internal combustion engine discharges carbon monoxide, a poisonous, odorless, invisible gas. Death or serious illness may result if inhaled. Operate only in an area with proper ventilation. **NEVER OPERATE IN A CONFINED AREA!**



DANGEROUS FUELS: Use extreme caution when storing, handling and using fuels, as they are highly volatile and explosive in vapour state. Do not add fuel while engine is running. Stop and cool the engine before adding fuel. **DO NOT SMOKE!**



SAFETY GUARDS: It is the operators's responsibility to ensure that all guards and shields are in place and in working order.



IGNITION SYSTEMS: Breakerless, magneto, and battery ignition systems can cause severe electrical shocks. Avoid contacting these units or their wiring.



SAFE DRESS: Do not wear loose clothing, rings, wristwatches, etc. near machinery.



NOISE PROTECTION: Wear OSHA specified hearing protection devices.



EYE PROTECTION: Wear OSHA specified eye shields, safety glasses, and sweat bands.



FOOT PROTECTION: Wear OSHA specified steel-tipped safety shoes.



HEAD PROTECTION: Wear OSHA specified safety helmets.



DUST PROTECTION: Wear OSHA specified dust mask or respirator.

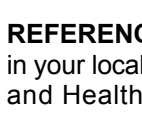

OPERATOR: Keep children and bystanders off and away from the equipment.

REFERENCES: For details on safety rules and regulations in your local area, contact your local Occupational Safety and Health Administration office. Equipment must be operated and serviced in accordance and compliance with any and all safety requirements that apply in your locality. The publication of these safety precautions is provided for your information. WINGET LIMITED does not by the publication of these precautions, imply or in any way represent that these are the sum of all dangers present near WINGET equipment. If you are operating WINGET equipment, it is your responsibility to insure that such operation is in full accordance with all applicable safety requirements and regulations.

Safety Decals

Carefully read and follow all safety decals. Keep them in good condition. If decals become damaged, replace as required. If repainting the unit, replace all decals. Decals are available from authorized WINGET distributors. Order the decal set listed on the following page(s).

V2006082

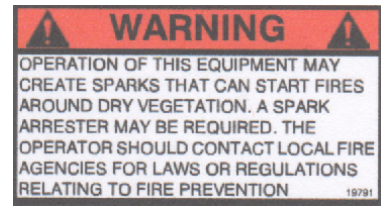
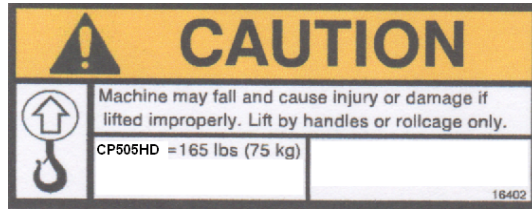

#19791

WINGET

#16402



#09311

CP505HD

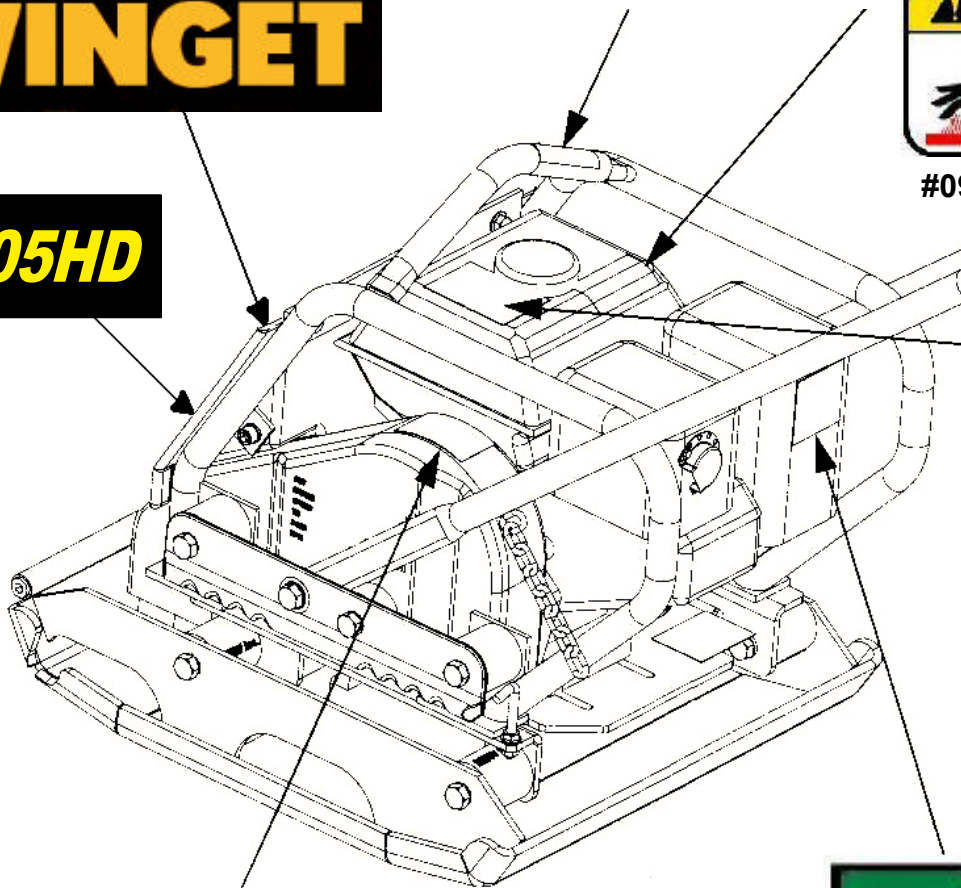

#13483



#12573



#13482

SPECIFICATIONS

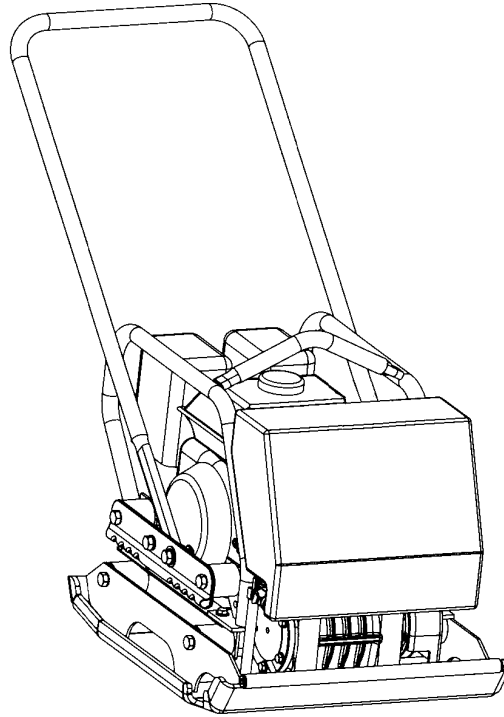

		CP505HD			
Operating Weight		165lbs (75kg)			
Plate Dimensions		20 x 22 x 21in (51 x 56 x 53cm)			
Centrifugal Force		3250lbf (1474kg)			
Exciter (VPM)		5050			
Travel Speed)		120ft/min (36m/min)			
Compaction Depth		14inch (36 cm)			
Engine Speed		3400 rpm			
Noise Levels		84 - 94 dBA			
Engine		Honda GX160			
Engine Power		5.5hp (4.0Kw)			

Specifications subject to change without notice

OPERATION

Introduction

WINGET equipment is intended for use in very severe applications. They are powered by four cycle engines and are available in different sizes.

This parts manual contains only standard parts. Variations of these parts as well as other special parts are not included. Contact your local WINGET distributor for assistance in identifying parts not included in this manual.

Before Starting & Operating

REMEMBER! It is the owners responsibility to communicate information on the safe use and proper operation of this unit to the operators.

Review ALL of the Safety Precautions listed on page 1 of this manual.

Familiarize yourself with the operation of the machine and confirm that all controls function properly.

Know how to STOP the machine in case of an emergency.

Make sure hands, feet, and clothing are at a safe distance from any moving parts.

OIL LEVEL - Check the oil level in the engine. For more information see "Lubrication" under the respective engine operators manual or the Maintenance section of this manual.

AIR CLEANER- Check to ensure element is in good condition and properly installed.

FUEL SUPPLY-The engines on WINGET equipment require an automotive grade of clean, fresh, unleaded petrol/gasoline.

FUEL FILTER - If clogged or damaged, replace.
Starting the Engine

1. Open fuel valve.
3. Set throttle to idle.
4. Choke engine if necessary (you may not need to apply any to choke a warm engine).
5. Pull the starter rope repeatedly until engine starts.
6. Move choke lever to open position.
7. Allow the engine to warm up for one or two minutes

Operating

1. After engine warms up, pull throttle lever to fully accelerate engine rpm. Plate will begin vibrating and moving in a forward direction.
2. The number of passes need to reach the compaction level desired, depends on the machine model, soil type, and moisture content. Maximum compaction of the soil has been reached when excessive kickback is noticed in the compactor or when indicated by soil testing methods. The unit is intended for use on loose gravel, ground, or aggregate. DO NOT operate on extremely hard surfaces such as concrete.
3. This unit is designed to operate on nominally level surfaces. The operator must take necessary precautions when working on sloped surfaces to prevent personal injury and/or damage to the unit. The compactor cannot advance up inclines.
4. If a significant amount of dust is being created from the operations it is recommended that the operator wear a dust mask or other suitable RPE.

Lifting/Transportation

1. The unit may be lifted by the upper section of the engine cage as indicated in the Decal Locations section of the manual. Do not lift the unit by the handle assembly as it may cause injury or damage.
2. The unit should be transported in the upright position and secured or tied down by the engine cage or roll cage. DO NOT lay the machine on its sides or top.

LIFT & SECURE HERE

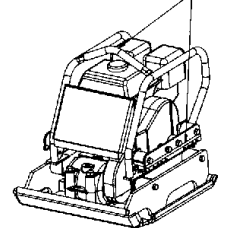

Stopping Engine

1. Move throttle to the idle position.
2. Let engine idle for one or two minutes.
3. Turn the engine switch to "off"



WARNING



Always stop the engine before:

Adding fuel.

Leaving the equipment unattended for any amount of time.

Before making any repairs or adjustments to the machine.

MAINTENANCE

⚠ WARNING ⚠

Always exercise the stopping procedure before servicing or lubricating the unit.

After servicing the unit, replace and fasten all guards, shields, and covers to their original positions before resuming operation.

⚠ CAUTION ⚠

Always verify fluid levels and check for leaks after changing fluids.

Do not drain oil onto ground, into open streams, or down sewage drains.

Maintenance Schedule

SYSTEM	MAINTENANCE	EACH USE	EVERY 50 HOURS	EVERY 250 HOURS	YEARLY
Engine	Refer to engine operator/owner manual	X			
Exciter	Check oil level		X		
	Check for oil leaks	X			
	Change oil			X	X
	Tighten Bolts ¹		X		X
Hardware	Check and tighten as needed ¹		X		X
Shock mounts	Check for cracks or tears		X		X

Check all hardware after the first 5 hours of use, then follow the maintenance schedule.

Fluid Levels

SYSTEM	FLUID VOLUME	RECOMMENDED OIL
Exciter	6 oz.	WINGET [®] Exciter Oil ¹
Engine	Refer to engine operator/owner manual	

WINGET #01058---- 6-Pack (8 oz. bottles)
WINGET #17320---- 1 quart (32 oz.)

Engine Maintenance

Refer to the Engine Operators Manual for intervals and procedures.

Disassembly Instructions

⚠ CAUTION ⚠

Assembly and Disassembly should be performed by a service technician who has been factory trained on WINGET equipment.

Cleaning Plate

The unit should be clean and free of debris, especially around exciter covers, to prevent foreign materials from entering the internal unit assemblies. Steam cleaning is recommended.

Engine Speed

1. Engine speed is factory set according to the speed listed in the Specification section of this manual. Do not tamper with the governor setting, the governor establishes safe operating limits which must not be exceeded.
2. Refer to Engine Operators Manual for the procedure on setting operating and idle speed.
3. The engine operating speed should be set to 3400 RPM.
4. The engine idle speed should not exceed 1800 rpm, if the idle speed is greater than 1800 rpm the clutch may not dis-engage correctly.

Belt Adjustment

If any belt stretch develops, follow these steps:-
Reference engine assembly page.

1. Remove the 4 flange bolts securing roll cage assembly to engine deck and remove cage assembly. Refer to figure 1

2. Apply moderate thumb pressure to the belt about half way between the pulleys. When correctly adjusted the belt should deflect approximately 3/8" (9mm). If the belt is adjusted correctly reinstall belt guard and hardware.
3. To adjust belt tension, loosen (do not remove) the (4) engine bolts.
4. Push engine towards the back of the plate. While holding pressure on the engine retighten the (4) engine bolts.
5. Recheck the belt tension as described in step 2 and readjust if necessary until the proper tension is reached.
6. Reinstall the roll cage assembly.

Checking Exciter Oil



The Exciter and oil are hot after machine has been running. Allow machine to cool before servicing.

1. Let exciter cool before checking oil level.
2. Place the plate on a level surface.
3. Remove roll cage assembly by removing (4) flange screws securing cage to engine deck. Lift entire roll cage assembly including cage, belt guard and handle can be removed, see figure 1 below

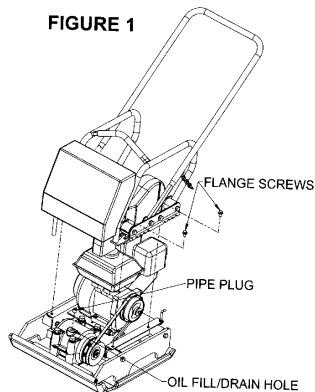

4. Clean all debris from the exciter to prevent contamination of the exciter oil.
5. Remove pipe plug from top of exciter housing.
6. Rotate exciter shaft to allow metal dipstick to be inserted into exciter, refer to figure 2 below.

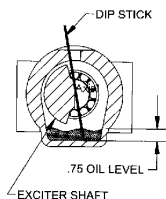

7. Pass a clean metal rod through the oil filler hole as shown, oil level should be 3/4" on dipstick.
8. Refer to Fluid Levels in Specifications for type of oils to be used. Do not overfill, this can cause excess heat.

9. Apply pipe sealant to pipe plug and reinstall into top of exciter.
10. Reinstall roll cage assembly.

Changing Exciter Oil



The Exciter and oil are hot after machine has been running. Allow machine to cool before servicing.

1. Let exciter cool before changing oil.
2. Place the plate on a level surface.
3. Remove roll cage assembly by removing (4) flange screws securing cage to engine deck. Lift entire roll cage assembly including cage, belt guard and handle can be removed, see figure 1.
4. Remove 1/2" hex head cap screws and lock washers from side of bottom plate. Remove belt and engine deck assembly, refer to figure 3 below.

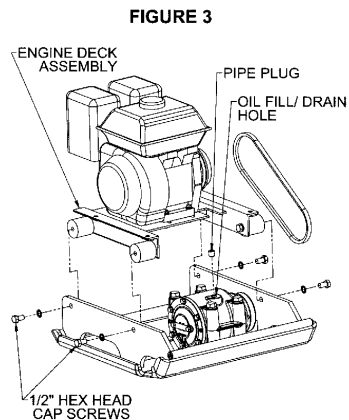

5. Remove plug from top of exciter housing, turn plate housing upside down to drain oil from housing.
7. Return plate to the upright position.
8. Fill exciter with exciter oil as specified under Fluids on Specifications page, using clean metal dipstick to ensure oil level is correct as described under checking exciter oil levels.
9. Apply pipe sealant to pipe plug and reinstall into top of exciter housing.
10. Reinstall engine deck assembly, belt, check and adjust belt tension as previously described if necessary.
11. Reinstall roll cage assembly

SERVICE

Assembly and disassembly should be performed by a service technician who has been factory trained on WINGET equipment. The unit should be clean and free of debris. Pressure washing before disassembly is recommended.

Prior to assembly, wash all parts in a suitable cleaner or solvent.

Check moving parts for wear and failure. Refer to the Replacement section in this manual for tolerance and replacement cycles.

All shafts and housings should be oiled prior to pressing bearings. Also, ensure that the bearings are pressed square and are seated properly.

All bearings should be replaced when rebuilding any exciter or gearbox.

All gaskets and seals should be replaced after any disassembly.

Torque Chart

SIZE	GRADE 2	GRADE 5	GRADE 8
1/4-20	49 in lbs	76 in lbs	9 ft lbs
1/4-28	56 in lbs	87 in lbs	10 ft lbs
5/16-18	8 ft lbs	13 ft lbs	18 ft lbs
5/16-24	9 ft lbs	14 ft lbs	20 ft lbs
3/8-16	15 ft lbs	23 ft lbs	33 ft lbs
3/8-24	17 ft lbs	26 ft lbs	37 ft lbs
7/16-14	24 ft lbs	37 ft lbs	52 ft lbs
7/16-20	27 ft lbs	41 ft lbs	58 ft lbs
1/2-13	37 ft lbs	57 ft lbs	80 ft lbs
1/2-20	41 ft lbs	64 ft lbs	90 ft lbs
9/16-12	53 ft lbs	82 ft lbs	115 ft lbs
5/8-11	73 ft lbs	112 ft lbs	159 ft lbs
5/8-18	83 ft lbs	112 ft lbs	180 ft lbs
3/4-16	144 ft lbs	200 ft lbs	315 ft lbs
1-8	188 ft lbs	483 ft lbs	682 ft lbs
1-14	210 ft lbs	541 ft lbs	764 ft lbs
1-1/2-6	652 ft lbs	1462 ft lbs	2371 ft lbs
M 6	3 ft lbs	4 ft lbs	7 ft lbs
M 8	6 ft lbs	10 ft lbs	18 ft lbs
M 10	10 ft lbs	20 ft lbs	30 ft lbs

CONVERSIONS

in lbs x 0.083 = ft lbs

ft lbs x 12 = in lbs

ft lbs x 0.1383 = kg m

ft lbs x 1.3558 = N m

Service Tools

Part No.	Description
01058	6 -Pack Exciter Oil
01629	Test Mat, Rubber

Exciter Removal

1. Remove roll cage assembly, engine deck and belt as described previously on page 6, changing exciter oil.
2. Remove 4 5/8-11 exciter bolts, washers, lock washers and nuts. If unit has exciter shims make a note of the location to assure correct placement during reassembly
3. Clean the exciter and drain the oil before proceeding with disassembly.

Refer to the illustrated parts page to assist in exciter disassembly.

Exciter Disassembly

1. Remove flange screw (23) and washer (8) securing the pulley (19) to the exciter shaft (20).
 2. Slide the pulley off the shaft ensuring the key (17) is not mislaid.
 3. Remove 6 flange screws (23) from rear cover plate (2) and remove cover, opposite of pulley end.
 4. Support the exciter assembly on outer diameter of exciter housing (1) and press shaft out of housing.
 5. Remove 6 flange screws (22) from front cover plate (18) and remove front cover.
- NOTE: if bearings have failed and need to be replaced then proceed with bearing removal steps. If bearings do not need replacing skip to step #9.**
6. Support exciter housing (1) and press out front bearing (4).
 7. Remove front bearing (4) inner race from exciter shaft by supporting O.D. of race and pressing exciter shaft through bearing race.
 8. Remove snap ring (6) and press rear bearing off of shaft (20).
 9. When reassembling always replace, oil seal (13) and front and rear cover gaskets (10 & 11)

Exciter Re-assembly

Refer to the illustrated parts page to assist in exciter reassembly.

1. Clean all components in a suitable solvent or cleaning solution, replace all seals and gaskets.

Note: if replacing bearings proceed to step #2, if not replacing bearings skip to step #6

2. Press front bearing (4) inner race onto exciter shaft, pulley end.

3. Press front bearing (4) into exciter housing (1)

4. Press rear bearing (5) onto exciter shaft, opposite pulley end, use care to press on I.D. of bearing only.

5. Install snap ring (6) onto exciter shaft.

6. Press exciter shaft assembly into exciter housing (1). Use care to properly support O.D. of housing and guide shaft into bearing already seated in housing.

7. Press oil seal (13) into front cover (18), seal to be pressed in until it bottoms out on inside flange of front cover.

8. Install new gasket (10) front cover and 6 flange screws (22) . Torque flange screws to 13ft-lbs.

9. Install new gasket (11) rear cover and 6 flange screws (23). Torque flange screws to 13ft-lbs.

10. Grease lip of of oil seal (13) and exciter shaft. Install key (17) on shaft and slide pulley (19) onto shaft.

11. Install washer (8) and flange screw (23) torque flange screw to 13ft-lbs.

12. Fill exciter with oil to correct level as previously described, do not overfill.

Exciter Installation

Refer to the illustrated parts page to assist in exciter installation.

1. Clean exciter mounting bars on bottom plate, replace any exciter shims (3) in original position and set exciter assembly in place on mounting bars.

2. Check to ensure exciter sits true and flat on mounting bars if no shims (3) are fitted.

3. Install 4 5/8-11 exciter bolts, washers, lock washers and 5/8-11 nuts. Torque exciter bolts to 150ft-lbs.

4. Reinstall engine deck and belt if necessary adjust belt tension as previously described. Reinstall roll cage assembly.

Parts Replacement Cycles and Tolerances

Bearings	Replace anytime a bearing is rough, binding, discolored or removed from housing or shaft.
Clutch	Replace clutch if it does not disengage below 1800 rpm.
Engine Components	Refer to Engine Manufacturers Manual
Hardware	Replace any worn or damaged hardware as needed. Replacement hardware should be grade 5 and zinc plated unless otherwise specified.
Safety Decals	Replace if they become damaged or illegible.
Seals & Gaskets	Replace if a leak is detected and at every overhaul or tear down.
V-Belts	Replace if cracked, torn or stretched

REPLACEMENT PARTS

The warranty is stated in this book on page 20. Failure to return the Warranty Registration Card renders the warranty null and void.

WINGET has established a network of reputable distributors/dealers with trained mechanics and full facilities for maintenance and rebuilding, and to carry an adequate parts stock in all areas of the country. Their sales engineers are available for professional consultation. If you cannot locate a WINGET distributor in your area, contact WINGET as listed below.

When ordering replacement parts, be sure to have the following information available:

Model and Serial Number of machine when ordering WINGET parts

Model and Serial Number of engine when ordering engine parts

Part Number, Description, and Quantity

Company Name, Address, Zip Code, and Purchase Order Number

Preferred method of shipping

REMEMBER - You own the best! If repairs are needed, use only WINGET parts purchased from authorised WINGET distributors

Write Model Number here

Write Serial Number here

Contact Information

**WINGET Limited
PO Box 41
Edgefold Industrial Estate
Plodder Lane
Bolton, Lancs
BL4 0LR**

email: parts@winget.co.uk

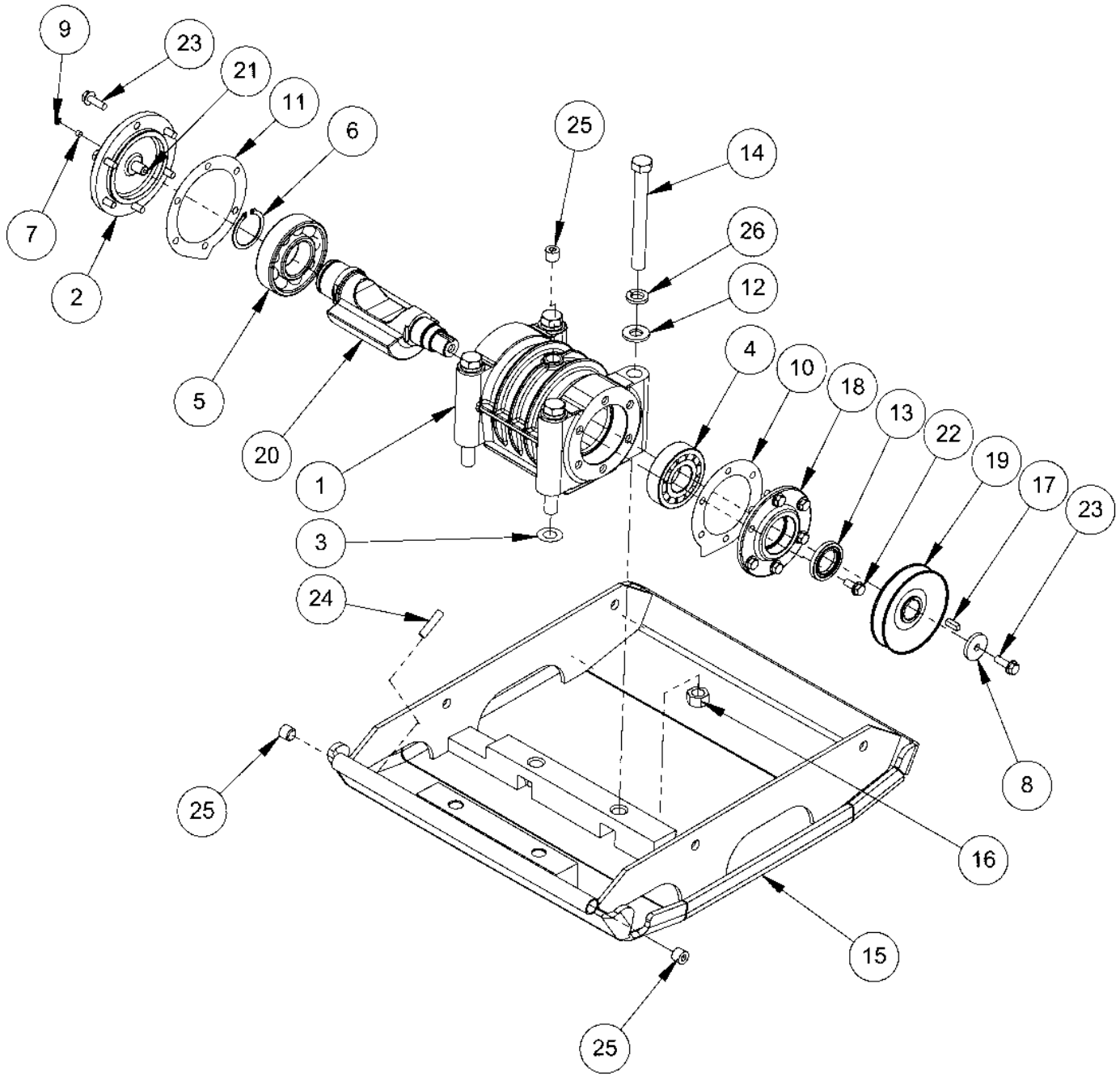

EXCITER ASSEMBLY

CP505HD Exciter Assembly

Item number.	Part number.	Product Description.	Quantity.
1	00201	Exciter Housing	1
2	00206	Rear Cover	1
3	00259	Shim Exciter (as required)	A/R
4	01004	Bearing, Cylindrical Roller	1
5	01070	Bearing, Ball	1
6	01071	Ring, Retaining External	1
7	01072	Filter, Felt	1
8	01099	Washer	1
9	01191	Ring, Retaining Internal	1
10	06096	Gasket	1
11	06097	Gasket	1
12	13451	Washer, Flat, 5/8"	4
13	01002	Seal, Oil up to S/No 2064574	1
13	17179	Seal, Oil from S/No 2064575	1
14	18696	Bolt, 5/8-11x5-3/4" Grade 8.8	4
15	18697	Plate, Base	1
16	18701	Nut, 5/8-11, Grade 8.8	4
17	01283	Key, Parallel 1/4SQx1-1/4 Round Ends, up to S/No 2064574	1
17	19135	Key, Parallel 1/4SQx3/4 Square Ends, from S/No 2064575	1
18	00005	Front Cover up to S/No 2064574	1
18	19628	Front Cover from S/No 2064575	1
19	00348	Pulley, 3-7/8"dia x 1-1/8 I.D. Up to S/No 2064574	1
19	19630	Pulley, 3-7/8"dia x 1.0 I.D. from S/No 2064575	1
20	00202	Shaft, Exciter, up to S/No 2064574	1
20	19835	Shaft, Exciter, from S/No 2064575	1
21	F0205SP	Pin, Spirol 1/8" x 5/8"Lg	1
22	F051806FWS	Screw, Locking, Flange, 5/16- 18x1.0 Lg	6
23	F051808FWS	Screw, Locking, Flange, 5/16- 18x3/4 Lg	7
24	F0612SP	Pin, Spirol	1
25	F0618SPP	Plug, Socket, Pipe, 3/8-18	3
26	F10LW	Washer, Lock 5/8, ZP	4
		Service Parts	
	00062	Seal, Washer, Pulley, (Not Shown) up to S/No 2064574	
		Replacement Kits	
	19836	Exciter Assembly (Does not include items 8,17,19 & 23	
	18757	Plate, Bottom, (Includes items 3,12,14,15,16,24,25 & 26	

BOTTOM ENGINE
RECOIL SCREW
(HONDA ONLY)

ROBIN ENGINES
ONLY.

ENGINE ASSEMBLY

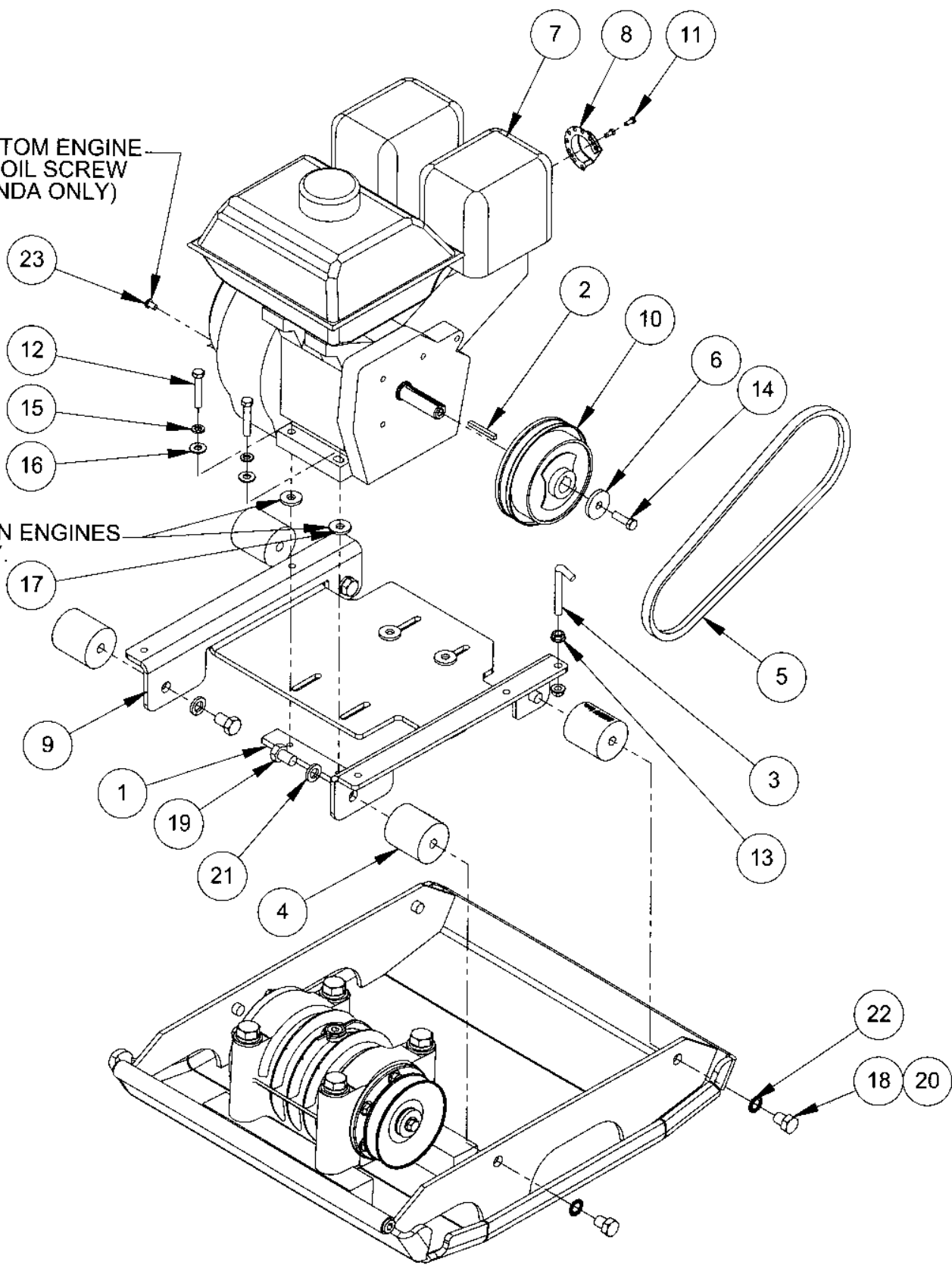

CP505HD Engine Assembly

Item number.	Part number.	Product Description.	Quantity.
1	00031	Bar, Mounting, Engine	2
2	00032	Key, Shaft, 3/16SQx1-5/8 Lg	1
3	00048	Bolt, Hook 5/16-18	1
4	01011	Mount, Shock	4
5	01013	Belt, V A-30	1
6	01099	Washer	1
7	01444	Engine, Honda, GX160	1
8	07636	Deflector, Exhaust	1
9	19531	Deck, Engine	1
10	16105	Clutch, Centrifugal	1
11	F0203HTB	Screw, #8-3/8 Lg Type A, Washer Head	2
12	F051814HCS	Bolt, 5/16-18x1-3/4 Lg, Grade 5	4
13	F0518FN	Nut, Flange, Locking, 5/16-18 Z.P.	2
14	F052408HCS	Screw Set, 5/16-18x1.0 Lg Z.P.	1
15	F05LW	Washer, Lock 5/16 Z.P.	4
16	F05SW	Washer, Flat 5/16 Z.P.	4
17	F06SW	Washer, Flat 3/8 Z.P.	4
18	F081305HCS	Screw, Set, 1/2-13x5/8 Lg, Grade5, Z.P.	4
19	F081306HCS	Screw, Set, 1/2-13x3/4 Lg, Grade5, Z.P.	4
20		Not Used	
21	F08LW	Washer, Lock 1/2 Z.P.	4
22	M12ETLW	Washer, Lock, M12, External Tooth	4
23	M06C010BCS	Screw, Button Head, M6x10mm	1
		Service Kits	
	20185	Kit, Service, Honda, CP505HD	
		4 x #01011 Mount, Shock	
		4 x #17170 Mount, Shock	
		1 x #01013 Belt V	
		1 x #19951 – Quart 10W/30 Oil	
		1 x #20186 Bottle Exciter Oil	
		1 x #Q17210ZE1822 Element Air Cleaner	
		1 x #Q9807956846 Plug, Spark	

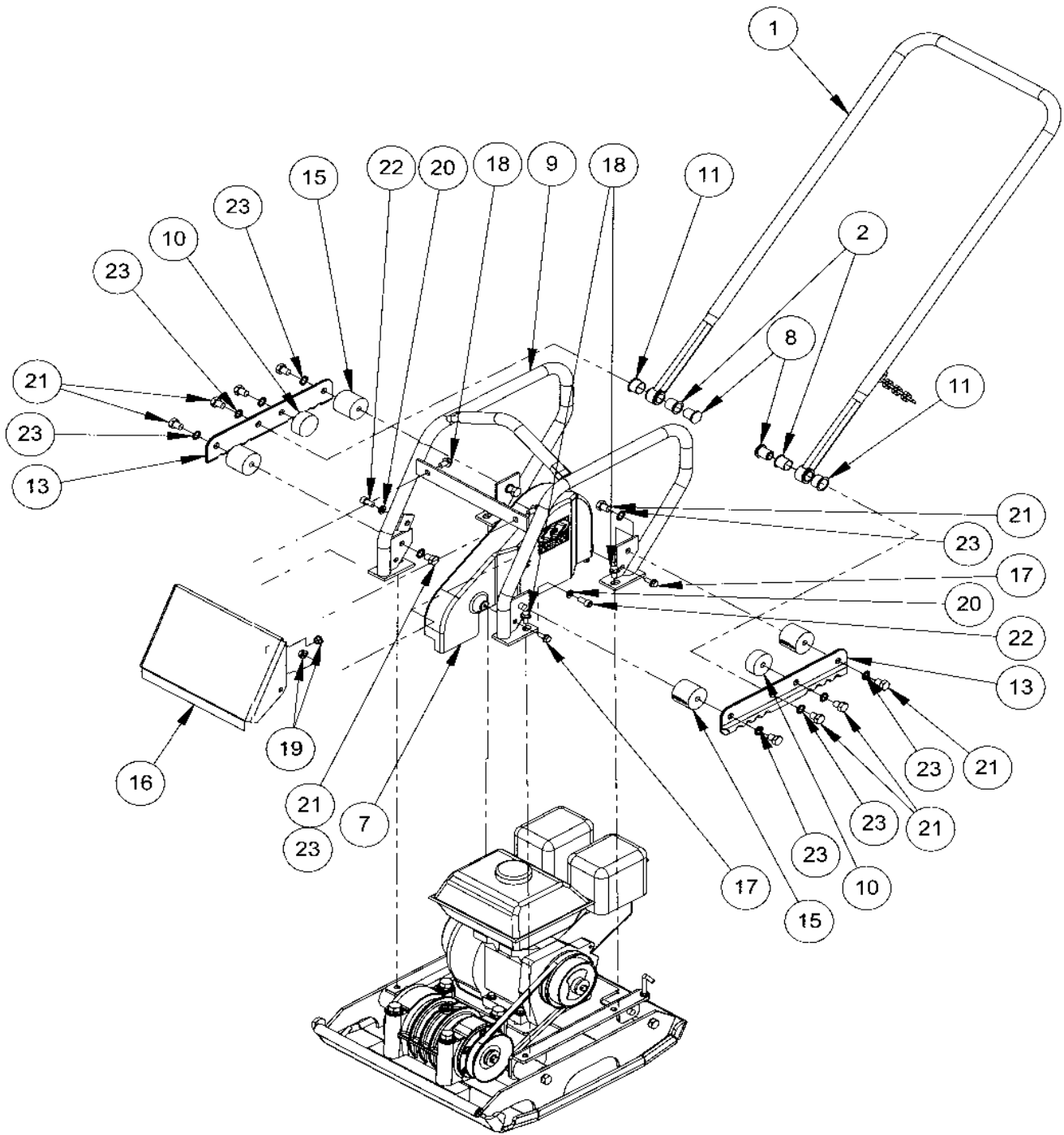

ROLL CAGE

Warranty.

This is your warranty document Please read and keep this document safe.

1. Winget Ltd warrants each new machine against defects in material and workmanship under normal use and service for a period of six (6) months. This warranty commences on the first day that the machine is sold, assigned to a hire fleet or otherwise put to first use.
2. The obligation under this warranty is limited to the replacement or repair of parts by Winget Limited or at authorised Winget Limited Distributor.
3. Machines altered or modified without the written consent of Winget Limited voids this warranty. Abuse, negligence, accidents, lack of maintenance or the operation of machines in any other way than we recommend will void this warranty. This warranty shall not apply to machines repaired by other than Winget Limited or one of our appointed Distributors unless authorised in writing.
4. This warranty includes labour on all Winget products. Labour operations must be performed by Winget Limited or one of our authorised Distributors.
5. The cost of transportation and any/all expenses connected therewith, are not covered by this warranty.
6. Winget Limited reserves the right to inspect and render final decision on each and every warranty claim.
7. Winget Limited reserves the right to improve or make product changes without incurring any obligation to update, refit, or install the same on previously sold machines.
8. Winget Limited will not be held responsible for any liability or damage or injury directly or indirectly from design, material or operation of its products.
9. The foregoing warranty is expressly in lieu of all other warranties, expressed or implied, including the warranties of merchantability and fitness for use, and of all other obligation or liabilities on our part. We neither assume, nor authorise any other person to assume for us any other liability or warranty in connection with the sale or service of any of our products. This warranty shall not apply in respect to engines, air-motors and other third party components.



WARNING



CALIFORNIA PROPOSITION 65 WARNING

Engine exhaust and some of its constituents
are known in the state of California to cause
cancer,

